

BELAIR

O-LEG DESK ASSEMBLY INSTRUCTIONS

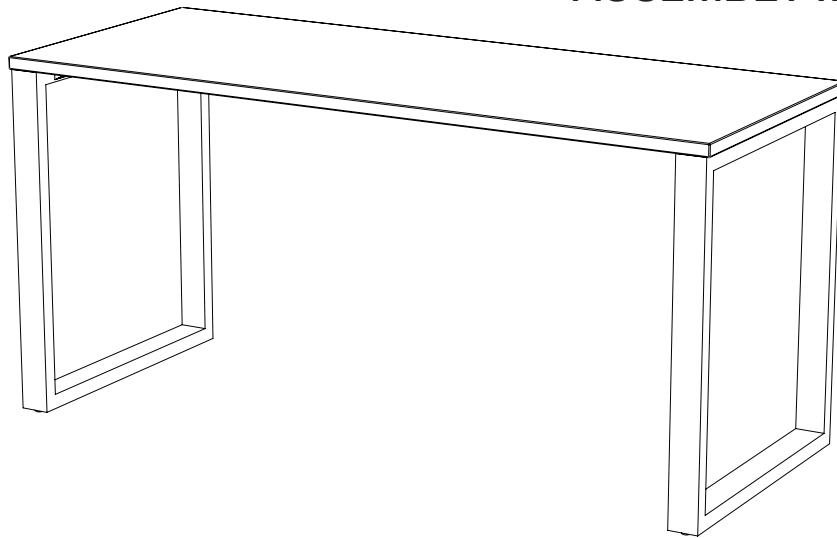

PARTS INCLUDED

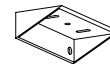
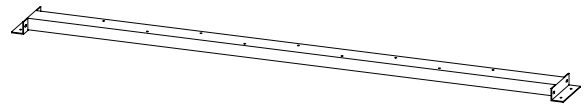
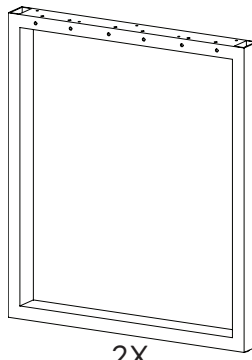
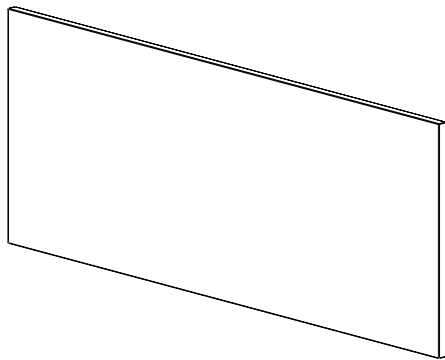

4X

HARDWARE INCLUDED

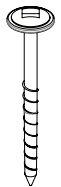

27X



12X



16X

TOOLS REQUIRED

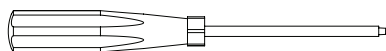

#2 Robertson Screwdriver



Allen Key

DISCLAIMER

- Two people are recommended for the assembly of this product.
- Use hardware provided and tools recommended to avoid any product faults.
- Always assemble product on a clean soft surface to avoid scratching.

STEP 1

Assemble O-legs and stiffener as shown with allen key provided. Loosely thread the bolts. This is important for later steps. Stiffener can be placed centered or off-centered to O-legs depending on desired layout.

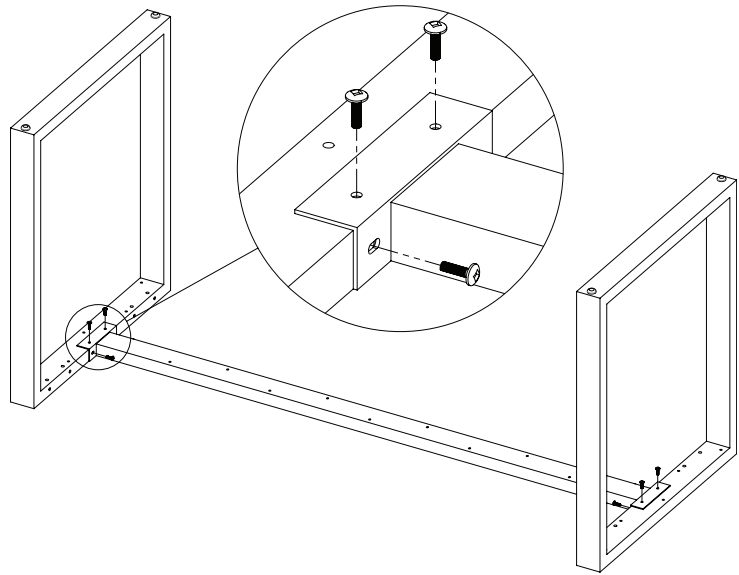

STEP 2

Lay desk top flat and center O-leg base onto top. Screw down one leg first ensuring that it is squared to the top. Then screw down the opposite leg ensuring that it is also squared to the top. The loosely bolted stiffener should allow room for the legs to be squared when being screwed down.

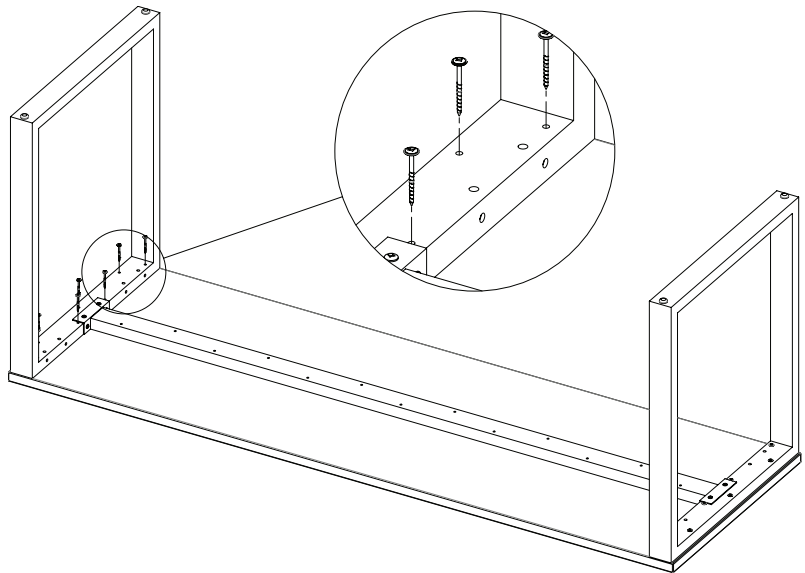

STEP 3

Connect triangle brackets to O-legs as shown with small bolts and allen key provided. Brackets and stiffener can be interchangeable depending on layout.

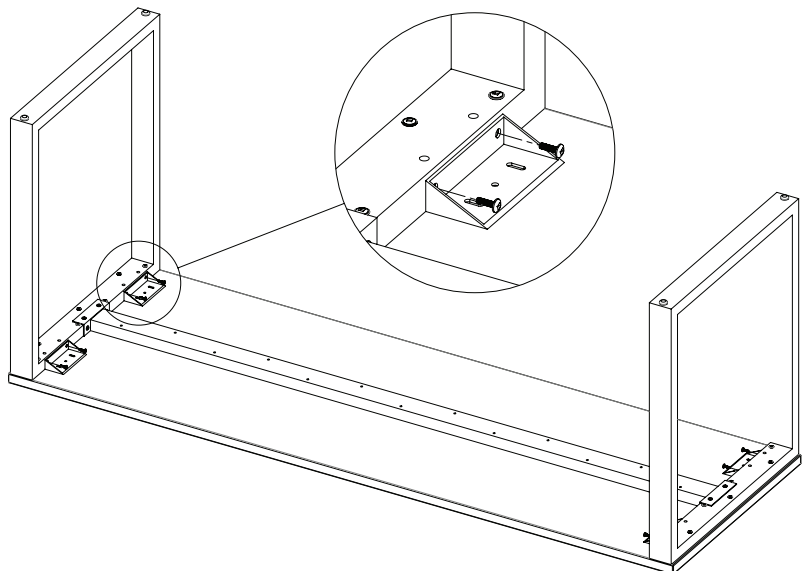

STEP 4

Next use small screws provided to screw the triangle brackets into the top.

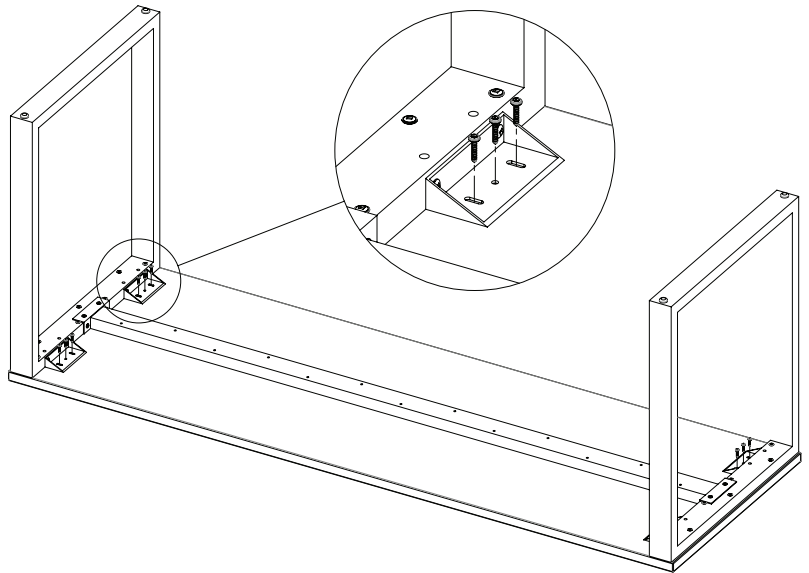

STEP 5

Once the legs and triangle brackets are secured the bolts connecting the stiffener to the O-legs can now be tightened. Secure the stiffener to the top with the remaining screws.

